

FA 90DHGT

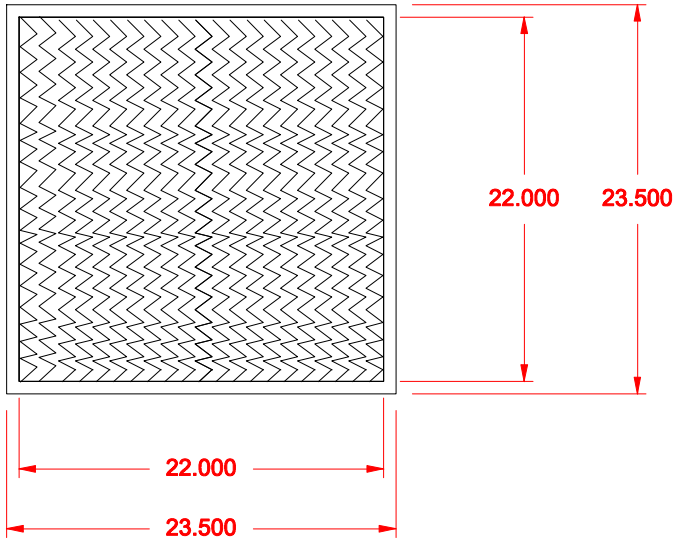

CONSTRUCTION:

FRAME AND HEADERS: 22 GAUGE GALVANIZED STEEL
FACE GUARDS: GALVANIZED STEEL ON BOTH SIDES
MEDIA: 165 SQUARE FEET 90% BOROSILICATE MICROGLASS
SEALANT: PVC PLASTISOL
PACKAGED: ONE PER BOX
WEIGHT: 24 LBS.

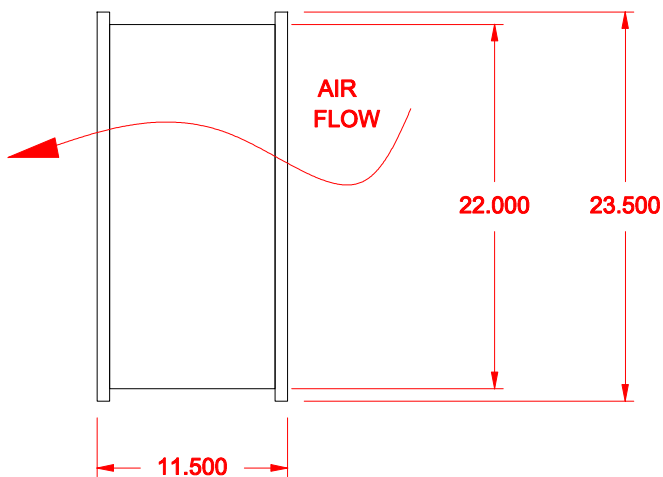

OPERATIONAL DATA:

MAXIMUM FLOW RATE: 2500 SCFM
CLEAN PRESSURE DROP AT 2500 SCFM: .89 INCHES WG.
CLEAN PRESSURE DROP AT 2000 SCFM: .68 INCHES WG.
RECOMMENDED FINAL RESISTANCE: 3.50 INCHES WG.
AVERAGE ATMOSPHERIC DUST SPOT EFFICIENCY: 93%
DUST HOLDING CAPACITY: 960 GRAMS AT 2.50 INCHES WG.
AVERAGE DUST WEIGHT ARRESTANCE: 98%
MERV 14